

23

Integrated Circuits

- 23.1 Integrated Circuit
- 23.2 Advantages and Disadvantages of Integrated Circuits
- 23.3 Inside an IC Package
- 23.4 IC Classifications
- 23.5 Making Monolithic IC
- 23.6 Fabrication of Components on Monolithic IC
- 23.7 Simple Monolithic ICs
- 23.8 IC Packings
- 23.9 IC Symbols
- 23.10 Scale of Integration
- 23.11 Some Circuits Using ICs

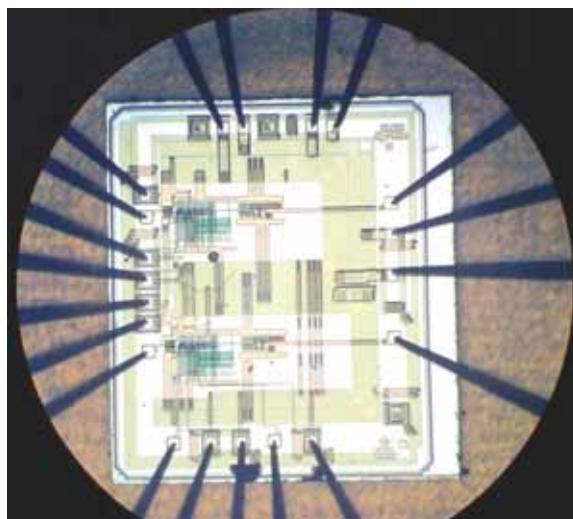

INTRODUCTION

The circuits discussed so far in the text consisted of separately manufactured components (*e.g.* resistors, capacitors, diodes, transistors *etc.*) joined by wires or plated conductors on printed boards. Such circuits are known as *discrete circuits* because each component added to the circuit is discrete (*i.e.* distinct or separate) from the others. Discrete circuits have two main disadvantages. Firstly, in a large circuit (*e.g.* TV circuit, computer circuit) there may be hundreds of components and consequently discrete assembly would occupy a large space. Secondly, there will be hundreds of soldered points posing a considerable problem of reliability. To meet these problems of space conservation and reliability, engineers started a drive for miniaturized circuits. This led to the development of *microelectronics* in the late 1950s.

Microelectronics is the branch of electronics engineering which deals with micro-circuits. A micro-circuit is simply a miniature assembly of electronic components. One type of such circuit is the *integrated circuit*, generally abbreviated as *IC*. An integrated circuit has various components such as resistors, capacitors, diodes, transistors *etc.* fabricated on a small semiconductor chip. How circuits containing hundreds of components are fabricated on a small semiconductor chip to produce

628 ■ Principles of Electronics

an IC is a fascinating feat of microelectronics. This has not only fulfilled the everincreasing demand of industries for electronic equipment of smaller size, lighter weight and low power requirements, but it has also resulted in high degree of reliability. In this chapter, we shall focus our attention on the various aspects of integrated circuits.

23.1 Integrated Circuit

An **integrated circuit** is one in which circuit components such as transistors, diodes, resistors, capacitors etc. are automatically part of a small semiconductor chip.

An integrated circuit consists of a number of circuit components (e.g. transistors, diodes, resistors etc.) and their inter connections in a single small package to perform a complete electronic function. These components are formed and connected within a small chip of semiconductor material. The following points are worth noting about integrated circuits :

(i) In an IC, the various components are automatically part of a small semi-conductor chip and the individual components cannot be removed or replaced. This is in contrast to discrete assembly in which individual components can be removed or replaced if necessary.

(ii) The size of an IC is extremely small. In fact, ICs are so small that you normally need a microscope to see the connections between the components. Fig. 23.1 shows a typical semi-conductor chip having dimensions $0.2\text{ mm} \times 0.2\text{ mm} \times 0.001\text{ mm}$. It is possible to produce circuits containing many transistors, diodes, resistors etc. on the surface of this small chip.

(iii) No components of an IC are seen to project above the surface of the chip. This is because all the components are formed within the chip.

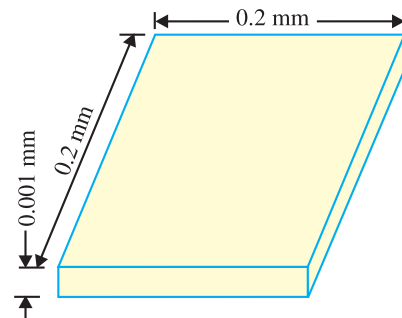

Fig. 23.1

23.2 Advantages and Disadvantages of Integrated Circuits

Integrated circuits free the equipment designer from the need to construct circuits with individual discrete components such as transistors, diodes and resistors. With the exception of a few very simple circuits, the availability of a large number of low-cost integrated circuits have largely rendered discrete circuitry obsolete. It is, therefore, desirable to mention the significant advantages of integrated circuits over discrete circuits. However, integrated circuits have some disadvantages and continuous efforts are on to overcome them.

Advantages : Integrated circuits possess the following advantages over discrete circuits :

(i) Increased reliability due to lesser number of connections.

(ii) Extremely small size due to the fabrication of various circuit elements in a single chip of semi-conductor material.

(iii) Lesser weight and **space requirement due to miniaturized circuit.



Integrated circuits

* Since it combines both active (e.g., transistors, diodes etc.) and passive elements (e.g., resistors, capacitors etc.) in a monolithic structure, the complete unit is called an integrated circuit.

** Typically, this is about 10% of the space required by comparable discrete assembly.

- (iv) Low power requirements.
- (v) Greater ability to operate at extreme values of temperature.
- (vi) Low cost because of simultaneous production of hundreds of alike circuits on a small semi-conductor wafer.
- (vii) The circuit lay out is greatly simplified because integrated circuits are constrained to use minimum number of external connections.

Disadvantages : The disadvantages of integrated circuits are :

- (i) If any component in an *IC* goes out of order, the whole *IC* has to be replaced by the new one.
- (ii) In an *IC*, it is neither convenient nor economical to fabricate capacitances exceeding 30 *pF*. Therefore, for high values of capacitance, discrete components exterior to *IC* chip are connected.
- (iii) It is not possible to fabricate inductors and transformers on the surface of semi-conductor chip. Therefore, these components are connected exterior to the semi-conductor chip.
- (iv) It is not possible to produce high power *ICs* (greater than 10 W).
- (v) There is a lack of flexibility in an *IC* *i.e.*, it is generally not possible to modify the parameters within which an integrated circuit will operate.

23.3 Inside an IC Package

The *IC* units are fast replacing the discrete components in all electronic equipment. These are similar to the discrete circuits that they replaced. However, there are some points to be noted. An integrated circuit (*IC*) usually contains only transistors, diodes and resistors. It is usually very difficult to form inductors in an *IC*. Also, only very small capacitors, in the picofarad range, can be included. When inductors and large values of *C* are needed, they are connected externally to an *IC*. The various components in an *IC* are so small that they cannot be seen with a naked eye. Therefore, individual components cannot be removed or replaced. If a single component within an *IC* fails, the complete *IC* is replaced. When studying circuits using *ICs*, we are more concerned with the external connections to the *ICs* than with what is actually going on inside. We cannot get into an *IC* to repair its internal circuitry.

23.4 IC Classifications

Four basic types of constructions are employed in the manufacture of integrated circuits, namely ;

- (i) mono-lithic (ii) thin-film (iii) thick-film (iv) hybrid.

Monolithic *ICs* are by far the most common type used in practice. Therefore, in this chapter we shall confine our attention to the construction of this type of *ICs* only. It may be worthwhile to mention here that regardless of the type of method used to fabricate active and passive components, the basic characteristics and circuit operation of an *IC* are the same as for any of their counterparts in a similar circuit using separate circuit components.

23.5 Making Monolithic IC

A **monolithic IC** is one in which all circuit components and their inter-connections are formed on a single thin wafer called the substrate.

The word monolithic is from Greek and means “one stone.” The word is appropriate because all the components are part of one chip. Although we are mainly interested in using *ICs*, yet it is profitable to know something about their fabrication. The basic production processes for the monolithic *ICs* are as follow :

- (i) **p-Substrate.** This is the first step in the making of an *IC*. A cylindrical *p*-type *silicon crystal is grown having typical dimensions 25 cm long and 2.5 cm diameter [See Fig. 23.2 (i)]. The crystal is then cut by a diamond saw into many thin wafers like Fig. 23.2 (ii), the typical thickness of

* Since silicon possesses characteristics which are best suited to *IC* manufacturing processes.

630 ■ Principles of Electronics

the wafer being 200 μm . One side of wafer is polished to get rid of surface imperfections. This wafer is called the substrate. The ICs are produced on this wafer.



Fig. 23.2

(ii) Epitaxial n layer. The next step is to put the wafers in a diffusion furnace. A gas mixture of silicon atoms and pentavalent atoms is passed over the wafers. This forms a thin layer of n -type

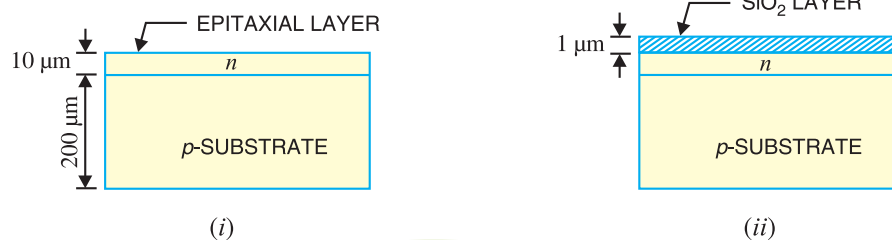

Fig. 23.3

semi-conductor on the heated surface of substrate [See Fig. 23.3 (i)]. This thin layer is called the **epitaxial layer* and is about 10 μm thick. It is in this layer that the whole integrated circuit is formed.

(iii) Insulating layer. In order to prevent the contamination of the epitaxial layer, a thin SiO_2 layer about 1 μm thick is deposited over the entire surface as shown in Fig. 23.3 (ii). This is achieved by passing pure oxygen over the epitaxial layer. The oxygen atoms combine with silicon atoms to form a layer of silicon dioxide (SiO_2).

(iv) Producing components. By the process of ***diffusion*, appropriate materials are added to the substrate at specific locations to produce diodes, transistors, resistors and capacitors. The production of these components on the wafer is discussed in Art 23.6.

(v) Etching. Before any impurity is added to the substrate, the oxide layer (*i.e.* SiO_2 layer) is etched. The process of etching exposes the epitaxial layer and permits the production of desired components. The terminals are processed by etching the oxide layer at the desired locations.

(vi) Chips. In practice, the wafer shown in Fig. 23.4 is divided into a large number of areas. Each of these areas will be a separate chip. The manufacturer produces hundreds of alike ICs on the wafer over each area. To separate the individual ICs, the

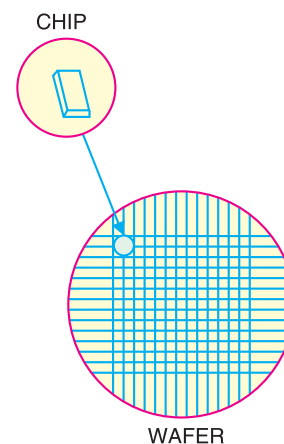

Fig. 23.4

* The word “epitaxial” is derived from the Greek language and means arranged upon.

** In IC construction, diffusion is the process of deliberately adding controlled impurities at specific locations of substrate by thermal processes.

wafer is divided into small chips by a process similar to glass cutting. This is illustrated in Fig. 23.4. It may be seen that hundreds of alike ICs can be produced from a small wafer. This simultaneous mass production is the reason for the low cost of integrated circuits.

After the chip is cut, it is bonded to its mounting and connections are made between the IC and external leads. The IC is then encapsulated to prevent it from becoming contaminated by the surrounding atmosphere.

23.6 Fabrication of Components on Monolithic IC

The notable feature of an IC is that it comprises a number of circuit elements inseparably associated in a single small package to perform a complete electronic function. This differs from discrete assembly where separately manufactured components are joined by wires. We shall now see how various circuit elements (e.g. diodes, transistors, resistors etc.) can be constructed in an IC form.

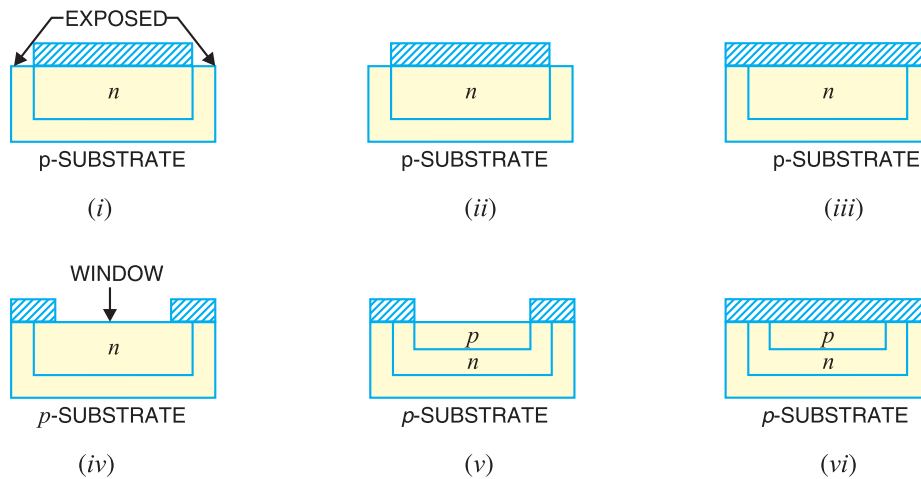

Fig. 23.5

(i) Diodes. One or more diodes are formed by diffusing one or more small *n*-type deposits at appropriate locations on the substrate. Fig. 23.5 shows how a diode is formed on a portion of substrate of a monolithic IC. Part of SiO_2 layer is etched off, exposing the epitaxial layer as shown in Fig. 23.5 (i). The wafer is then put into a furnace and trivalent atoms are diffused into the epitaxial layer. The trivalent atoms change the exposed epitaxial layer from *n*-type semi-conductor to *p*-type. Thus we get an island of *n*-type material under the SiO_2 layer as shown in Fig. 23.5 (ii).

Next pure oxygen is passed over the wafer to form a complete SiO_2 layer as shown in Fig. 23.5 (iii). A hole is then etched at the centre of this layer ; thus exposing the *n*-epitaxial layer [See Fig. 23.5 (iv)]. This hole in SiO_2 layer is called a **window**. Now we pass trivalent atoms through the window. The trivalent atoms diffuse into the epitaxial layer to form an island of *p*-type material as shown in Fig. 23.5 (v). The SiO_2 layer is again formed on the wafer by blowing pure oxygen over the wafer [See Fig. 23.5 (vi)]. Thus a *p-n* junction diode is formed on the substrate.

The last step is to attach the terminals. For this purpose, we etch the SiO_2 layer at the desired locations as shown in Fig 23.6 (i). By depositing metal at these locations, we make electrical contact with the anode and cathode of the integrated diode. Fig. 23.6 (ii) shows the electrical circuit of the diode.



Fig. 23.6

(ii) Transistors. Transistors are formed by using the same principle as for diodes. Fig. 23.7 shows how a transistor is formed on a portion of the substrate of a monolithic IC. For this purpose, the steps used for fabricating the diode are carried out upto the point where *p* island has been formed and sealed off [See Fig. 23.5 (vi) above]. This Fig. is repeated as Fig. 23.7 (i) and shall be taken as the starting point in order to avoid repetition.

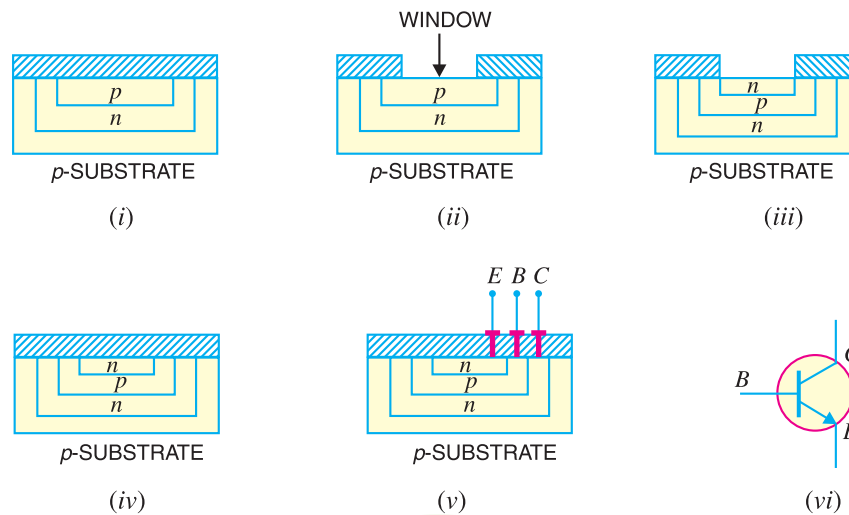

Fig. 23.7

A window is now formed at the centre of SiO_2 layer, thus exposing the *p*-epitaxial layer as shown in Fig. 23.7(ii). Then we pass pentavalent atoms through the window. The pentavalent atoms diffuse into the epitaxial layer to form an island of *n*-type material as shown in Fig. 23.7 (iii). The SiO_2 layer is re-formed over the wafer by passing pure oxygen [See Fig. 23.7 (iv)]. The terminals are processed by etching the SiO_2 layer at appropriate locations and depositing the metal at these locations as shown in Fig. 23.7 (v). In this way, we get the integrated transistor. Fig. 23.7 (vi) shows the electrical circuit of a transistor.

(iii) Resistors. Fig. 23.8 shows how a resistor is formed on a portion of the substrate of a monolithic IC. For this purpose, the steps used for fabricating diode are carried out upto the point where *n* island has been formed and sealed off [Refer back to Fig. 23.5 (iii)]. This figure is repeated as Fig. 23.8 (i) and shall be taken as the starting point in order to avoid repetition.

A window is now formed at the centre of SiO_2 layer, thus exposing the *n*-epitaxial layer as shown in Fig. 23.8 (ii). Then we diffuse a *p*-type material into the *n*-type area as shown in Fig. 23.8 (iii). The SiO_2 layer is re-formed over the wafer by passing pure oxygen [See Fig. 23.8 (iv)]. The terminals are processed by etching SiO_2 layer at two points above the *p* island and depositing the metal at these locations [See Fig. 23.8 (v)]. In this way, we get an integrated resistor. Fig. 23.8 (vi) shows the electrical circuit of a resistor.

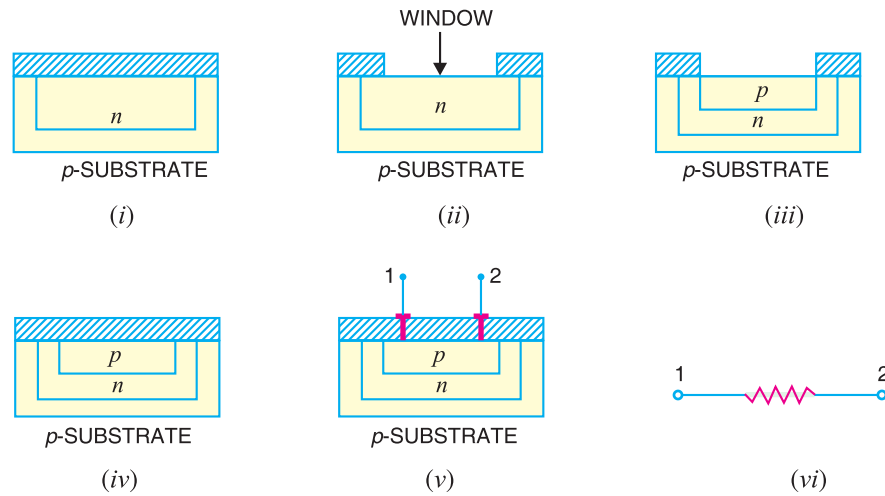

Fig. 23.8

The value of resistor is determined by the material, its length and area of cross-section. The high-resistance resistors are long and narrow while low-resistance resistors are short and of greater cross-section.

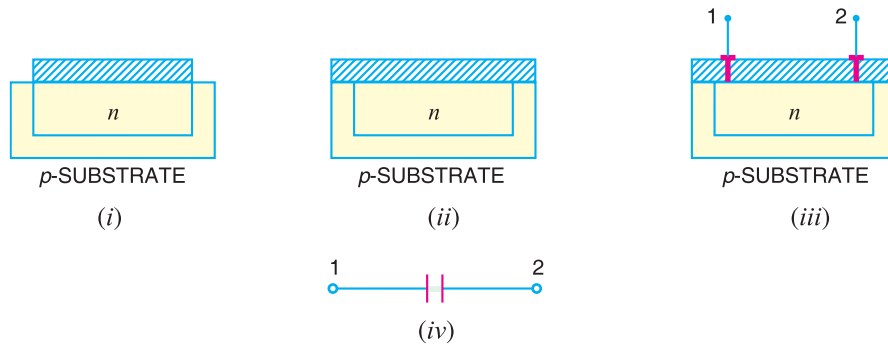

Fig. 23.9

(iv) Capacitors. Fig. 23.9 shows the process of fabricating a capacitor in the monolithic IC. The first step is to diffuse an n -type material into the substrate which forms one plate of the capacitor as shown in Fig. 23.9 (i). Then SiO_2 layer is re-formed over the wafer by passing pure oxygen as shown in Fig. 23.9 (ii).

The SiO_2 layer formed acts as the dielectric of the capacitor. The oxide layer is etched and terminal 1 is added as shown in Fig. 23.9 (iii). Next a large (compared to the electrode at terminal 1) metallic electrode is deposited on the SiO_2 layer and forms the second plate of the capacitor. The oxide layer is etched and terminal 2 is added. This gives an integrated capacitor. The value of capacitor formed depends upon the dielectric constant of SiO_2 layer, thickness of SiO_2 layer and the area of cross-section of the smaller of the two electrodes.

23.7 Simple Monolithic ICs

It has been seen above that individual components can be integrated in a monolithic IC. We shall now see how an electronic circuit comprising different components is produced in an IC form. The key point to keep in mind is that regardless of the complexity of the circuit, it is mainly a process of etching windows, forming p and n islands, and connecting the integrated components.

634 ■ Principles of Electronics

(i) **Two-diode IC.** Fig. 23.10 (i) shows a two-diode IC with a common anode whereas Fig. 23.10 (ii) shows a two-diode IC with individual anode.

Two points are worth noting. Firstly, any circuit [like the one shown in Fig 23.10 (i) or Fig 23.10 (ii)] is not integrated individually ; rather hundreds of alike circuits are simultaneously fabricated on a wafer. The wafer is then cut into chips so that each chip area represents one circuit. This is the key factor for low cost of ICs and is exerting considerable influence on electronics engineers to switch over to IC technology. Secondly, ICs are usually not as simple as shown in Fig. 23.10. In fact, actual ICs contain a large number of components.

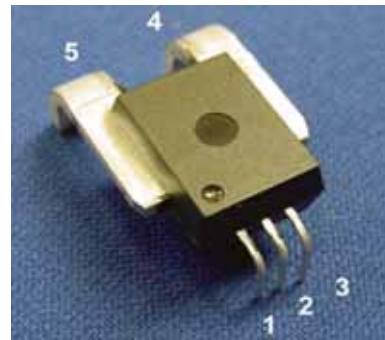

Monolithic IC

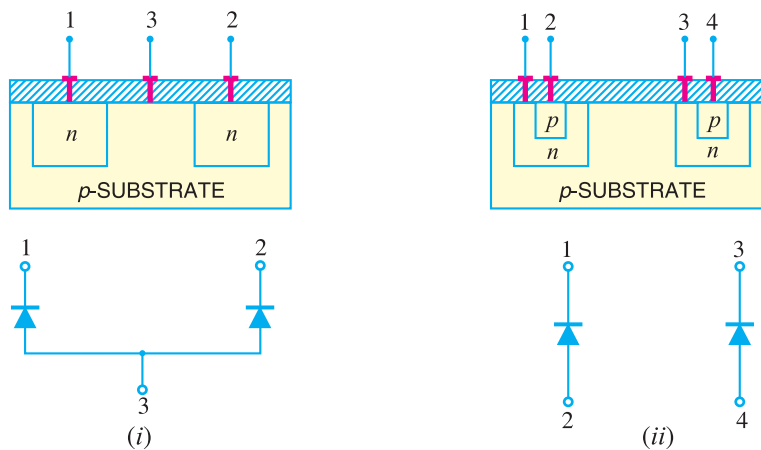

Fig. 23.10

(ii) **Another simple IC.** Fig.23.11 shows an IC consisting of a capacitor, resistor, diode and transistor connected in series. The interconnection of the circuit elements is accomplished by extending the metallic deposits from terminal to terminal of adjacent components.

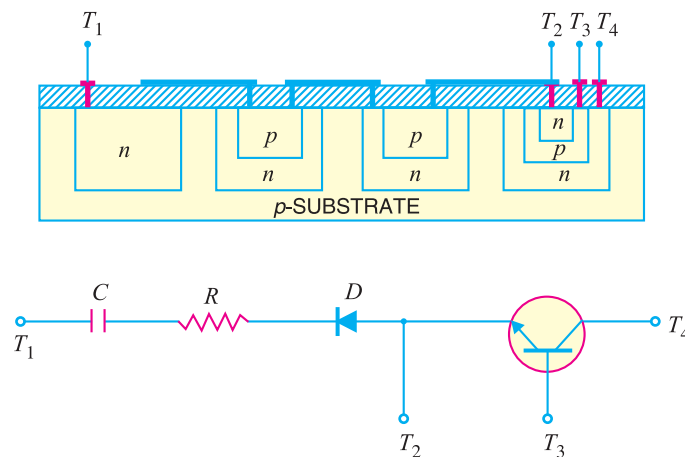

Fig. 23.11

It is interesting to see that p substrate isolates the integrated components from each other. Thus referring to Fig. 23.11, depletion layers exist between p substrate and the four n islands touching it. As the depletion layers have virtually no current carriers, therefore, the integrated components are insulated from each other.

23.8 IC Packings

In order to protect ICs from external environment and to provide mechanical protection, various forms of encapsulation are used for integrated circuits. Just as with semi-conductor devices, IC packages are of two types viz.

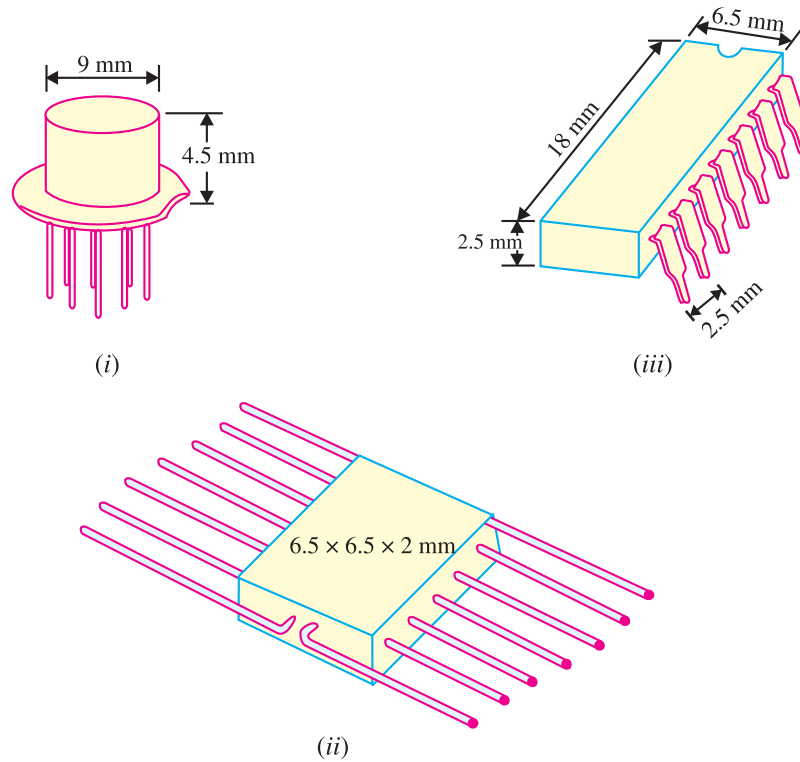

Fig. 23.12

- (i) hermetic (metal or ceramic with glass)
- (ii) non-hermetic (plastics)

Plastics are cheaper than hermetic but are still not regarded as satisfactory in extremes of temperature and humidity. Although ICs appeared in the market several years ago, yet the standardisation of packages started only in the recent years. The three most popular types of IC packages are shown in Fig. 23.12.

(i) Fig. 23.12 (i) shows *TO-5 package** which resembles a small signal transistor in both appearance and size but differs in that it has either 8, 10 or 12 pigtail-type leads. The close leads spacing and the difficulty of removal from a printed circuit board has diminished the popularity of this package with the users.

(ii) Fig. 23.12 (ii) shows a *flat pack* container with 14 leads, seven on each side.

(iii) Fig. 23.12 (iii) shows the *dual-in-line (DIL)* pack in 14-lead version. The 14-pin DIL is the

* This was the earliest type of package and it was natural for the semi-conductor manufactures to use modified transistor cases.

636 ■ Principles of Electronics

most popular form and has seven connecting pairs per side. The pairs of pins of this pack are in line with one another, the pins being 2.5 mm apart to allow *IC* to be fitted directly into the standard printed circuit boards.

23.9 IC Symbols

In general, no standard symbols exist for *ICs*. Often the circuit diagram merely shows a block with numbered terminals. However, sometimes standard symbols are used for operational amplifiers or digital logic gates. Some of the symbols used with *ICs* are shown below.

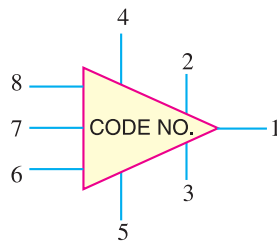

Fig. 23.13

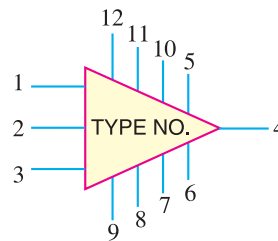

Fig. 23.14

Fig. 23.13 shows the symbol of an *IC r-f* amplifier containing 3 transistors, 3 resistors and 8 terminals. Similarly, Fig. 23.14 shows an *IC* audio amplifier which contains 6 transistors, 2 diodes, 17 resistors and has 12 terminals.

23.10 Scale of Integration

An *IC* chip may contain as large as 100,000 semiconductor devices or other components. The relative number of these components within the chip is given by referring to its scale of integration. The following terminology is commonly used.

Scale of integration	Abbreviation	Number of components
Small	*SSI	1 to 20
Medium	MSI	20 to 100
Large	LSI	100 to 1000
Very large	VLSI	1000 to 10,000
Super large	SLSI	10,000 to 100,000

23.11 Some Circuits Using ICs

Integrated circuits are fairly complex because they contain a large number of circuit components within a small semiconductor chip. While studying circuits using *ICs*, we are more concerned with the external connections to the *IC* rather than what is actually going on inside.

(i) **IC Fixed 5-volt Voltage Regulator.** The *IC* voltage regulator is a device that is used to hold the output voltage from a dc power supply constant as the input voltage or load current changes. For example, LM 309 (fixed positive) provides a + 5 V d.c. output. This regulator is frequently used in digital circuits. Fig. 23.15 shows the circuit of the voltage regulator using LM 309. It is a three terminal device with terminals labelled as input, output and ground terminal. It provides a fixed 5 V between the output and ground terminals.

* SSI stands for small scale integration.

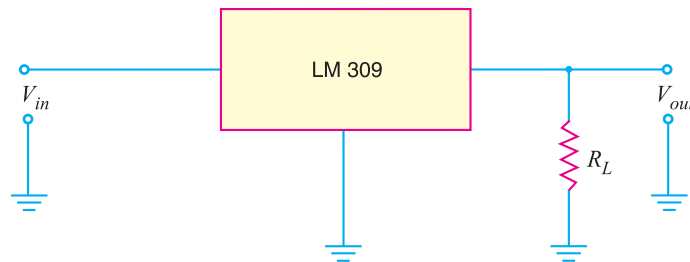

Fig. 23.15

The LM 309 has a number of advantages over the zener diode. First, it is much more accurate than the zener diode. Secondly, there is built-in overload protection. The LM 309 also has overheating protection. If the internal temperature becomes excessive, it shuts off until the temperature is reduced, at which point it will start up again.

(ii) IC Adjustable Voltage Regulator. Sometimes, we want a voltage regulator whose voltage we can vary. An example of such a voltage regulator is LM 317 whose schematic diagram is shown in Fig. 23.16. By varying the value of R_2 , the output voltage of the regulator can be adjusted. The following equation is used to determine the regulated d.c. output voltage for an LM 317 regulator circuit :

$$V_{out} = 1.25 \left(\frac{R_2}{R_1} + 1 \right)$$

Example 23.1. In LM 317 voltage regulator shown in Fig. 23.16, R_2 is adjusted to $2.4 \text{ k}\Omega$. If the value of R_1 is 240Ω , determine the regulated d.c. output voltage for the circuit.

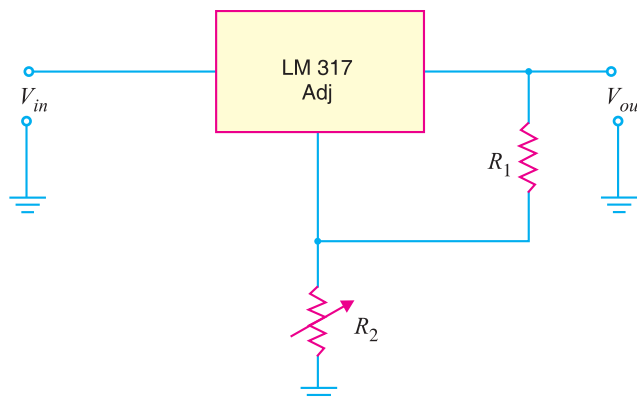

Fig. 23.16

Solution.

$$\begin{aligned} V_{out} &= 1.25 \left(\frac{R_2}{R_1} + 1 \right) \\ &= 1.25 \left(\frac{2.4 \text{ k}\Omega}{240 \Omega} + 1 \right) = \mathbf{13.75 \text{ V}} \end{aligned}$$

(iii) The 555 Timer as monostable multivibrator. Fig. 23.17 shows the circuit of the 555 timer as a monostable multivibrator. The R and C are the external components whose values determine the time T (in seconds) for which the circuit is on. This time is given by ;

$$T = 1.1 RC$$

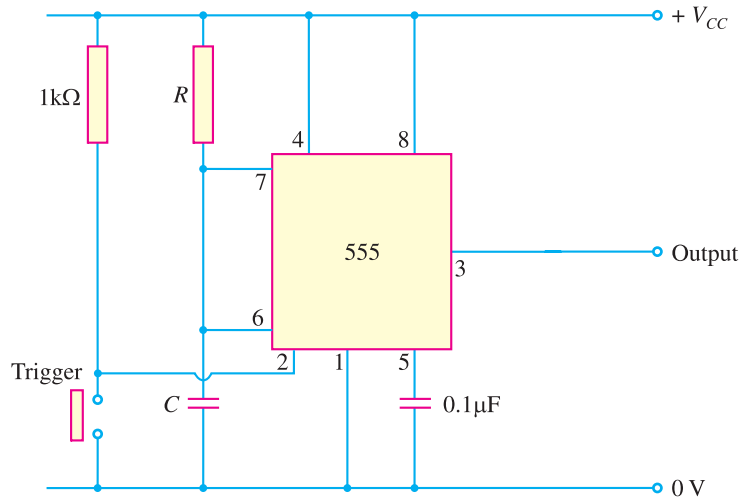

Fig. 23.17

Example 23.2. The monostable multivibrator like the one in Fig. 23.17 has the values of $R = 1.2\text{ k}\Omega$ and $C = 0.1\text{ }\mu\text{F}$. Determine the time T for which the circuit is on.

Solution. The time T for which the circuit is on is given by ;

$$T = 1.1 RC = 1.1(1.2 \times 10^3)(0.1 \times 10^{-6})$$

$$= 132 \times 10^{-6}\text{ s} = \mathbf{132\text{ }\mu\text{s}}$$

(iv) **The 555 Timer as astable multivibrator.** Fig. 23.18 shows the 555 timer as an astable multivibrator. Note that the circuit contains two resistors (R_1 and R_2) and one capacitor (C) and does not have an input from any other circuit. The lack of a triggering signal from an external source is the circuit recognition feature of the astable multivibrator.

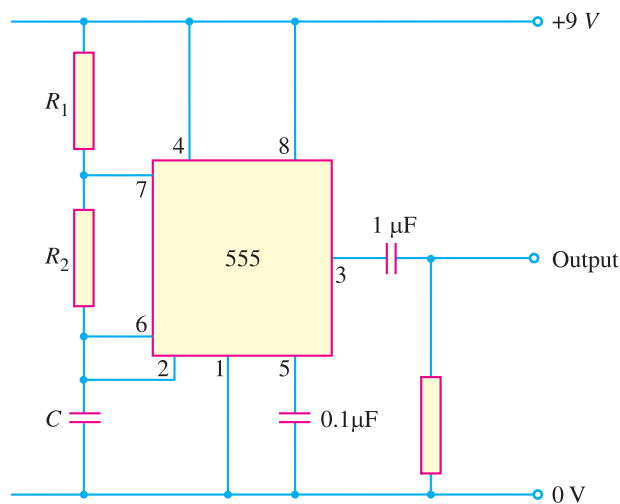

Fig. 23.18

The time T_1 for which the output is 'high' is given by ;

$$T_1 = 0.694 (R_1 + R_2) C$$

The time T_2 for which the output is 'low' is given by ;

$$T_2 = 0.694 R_2 C$$

∴ Total period T for the oscillation is

$$T = T_1 + T_2 = 0.694 (R_1 + 2 R_2) C$$

The frequency f of the astable multivibrator is given by ;

$$f = \frac{1}{T} = \frac{1}{0.694 (R_1 + 2R_2) C} = \frac{1.44}{(R_1 + 2R_2) C}$$

Note that f will be in Hz if resistance is in ohms and capacitance in farads.

Example 23.3. Determine the frequency of the circuit shown in Fig. 23.18. Given that $R_1 = 3 \text{ k}\Omega$; $R_2 = 2.7 \text{ k}\Omega$ and $C = 0.033 \text{ }\mu\text{F}$.

Solution. The frequency of the circuit is given by ;

$$f = \frac{1.44}{(R_1 + 2R_2) C}$$

Here

$$R_1 + 2R_2 = 3 \text{ k}\Omega + 2 \times 2.7 \text{ k}\Omega = 8.4 \times 10^3 \Omega ;$$

$$C = 0.033 \text{ }\mu\text{F} = 0.033 \times 10^{-6} \text{ F}$$

∴

$$f = \frac{1.44}{(8.4 \times 10^3) (0.033 \times 10^{-6})} = 5.19 \times 10^3 \text{ Hz} = \mathbf{5.19 \text{ kHz}}$$

(v) Op-Amp Half-wave Rectifier. Fig. 23.19 shows the half-wave rectifier using an *Op-Amp. The use of Op-Amp greatly reduces the effect of diode offset voltage and allows the circuit to be used in the millivolt region.

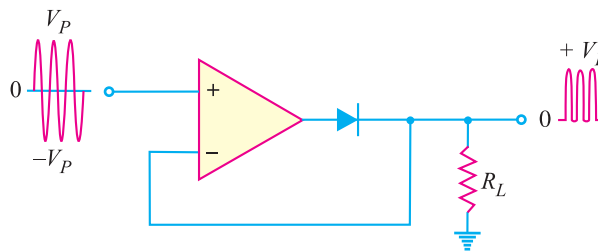

Fig. 23.19

When the input signal goes positive, the output of Op-Amp goes positive and turns on the diode. The circuit then acts like a voltage follower and the positive half-cycle appears across the load resistor R_L . On the other hand, when the input goes negative, the Op-Amp output goes negative and turns off the diode. Since the diode is open, no voltage appears across the load resistor R_L . Therefore, the voltage across R_L is almost a perfect half-wave signal.

(vi) Logarithmic amplifier. A logarithmic amplifier produces an output voltage that is proportional to the logarithm of the input voltage. If you place a **diode in the feedback loop of an Op-Amp as shown in Fig. 23.20, you have a log amplifier. The output is limited to a maximum value of about 0.7V because the diodes logarithmic characteristic is limited to voltages below 0.7V.

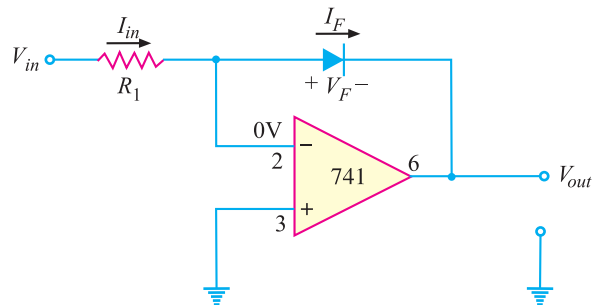

Fig. 23.20

* Now-a-days, Op-Amp is produced as an IC.
 ** The forward characteristic of a diode is logarithmic upto a forward voltage of about 0.7V.

640 ■ Principles of Electronics

Also, the input must be positive when the diode is connected in the direction shown in Fig. 23.20. To handle negative inputs, you should reverse the direction of the diode. It can be shown that the output voltage of the circuit shown is given by ;

$$V_{out} = -(0.025 \text{ V}) \log_e \left(\frac{V_{in}}{I_R R_1} \right)$$

where I_R = reverse leakage current of the diode

For example, if $V_{in} = +2 \text{ V}$, $R_1 = 100 \text{ k}\Omega$ and $I_R = 50 \text{ nA}$, then,

$$\begin{aligned} V_{out} &= -(0.025) \log_e \left(\frac{2\text{V}}{(50 \times 10^{-9})(100 \times 10^3)} \right) \\ &= -(0.025) \log_e (400) = -0.15 \text{ V} \end{aligned}$$

(vii) Constant-current source. A constant current source delivers a load current I_L that remains constant when the load resistance R_L changes. Fig. 23.21 shows the basic circuit of a constant current source. Since the inverting ($-$) input of the Op-Amp is at virtual ground (0V), the value of I_i is determined by V_{in} and R_i i.e.

$$I_i = \frac{V_{in}}{R_i}$$

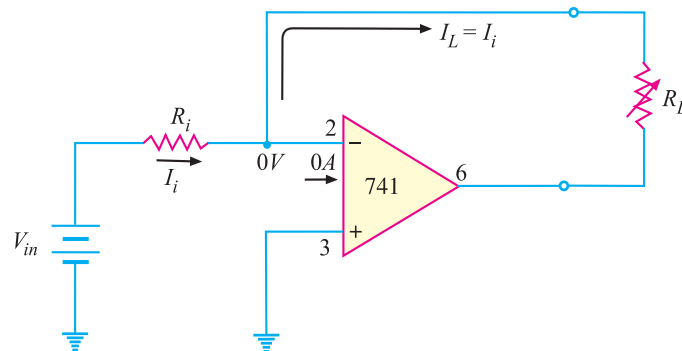

Fig. 23.21

The internal impedance of Op-Amp is extremely high (ideally infinite) so that practically all of I_i flows through R_L . Since $I_i = I_L$,

$$\therefore I_L = \frac{V_{in}}{R_i}$$

Note that load resistance R_L does not appear in this equation. Therefore, the load current (I_L) is independent of load resistance R_L . If R_L changes, I_L remains constant as long as V_{in} and R_i are held constant. In other words, the load is driven by a constant current source.

MULTIPLE-CHOICE QUESTIONS

- An IC has size.
 - very large
 - large
 - extremely small
 - none of the above
- ICs are generally made of
 - silicon
 - germanium
 - copper
 - none of the above
- ICs are the most commonly used.
 - thin film
 - monolithic
 - hybrid
 - none of the above

4. The most popular form of IC package is
 (i) DIL (ii) flatpack
 (iii) TO-5 (iv) none of the above
5. cannot be fabricated on an IC.
 (i) transistors (ii) diodes
 (iii) resistors
 (iv) large inductors and transformers
6. An audio amplifier is an example of
 (i) digital IC (ii) linear IC
 (iii) both digital and linear IC
 (iv) none of the above
7. The active components in an IC are
 (i) resistors (ii) capacitors
 (iii) transistors and diodes
 (iv) none of the above
8. We use ICs in computers.
 (i) digital (ii) linear
 (iii) both digital and linear
 (iv) none of the above
9. The SiO_2 layer in an IC acts as
 (i) a resistor
 (ii) an insulating layer
 (iii) mechanical output
 (iv) none of the above
10. ICs are used in
 (i) linear devices only
 (ii) digital devices only
 (iii) both linear and digital devices
 (iv) none of the above
11. A transistor takes inductor on a silicon IC chip.
 (i) less space than
 (ii) more space than
 (iii) same space as (iv) none of the above
12. The most popular types of ICs are
 (i) thin-film (ii) hybrid
 (iii) thick-film (iv) monolithic
13. Digital ICs process
 (i) linear signals only
 (ii) digital signals only
 (iii) both digital and linear signals
 (iv) none of the above
14. Operational amplifiers use
 (i) linear ICs (ii) digital ICs
 (iii) both linear and digital ICs
 (iv) none of the above
15. Which of the following is most difficult to fabricate in an IC ?
 (i) diode (ii) transistor
 (iii) FET (iv) capacitor

Answers to Multiple-Choice Questions

- | | | | | |
|----------|----------|-----------|----------|-----------|
| 1. (iii) | 2. (i) | 3. (ii) | 4. (ii) | 5. (iv) |
| 6. (ii) | 7. (iii) | 8. (i) | 9. (ii) | 10. (iii) |
| 11. (i) | 12. (iv) | 13. (iii) | 14. (ii) | 15. (iv) |

Chapter Review Topics

1. What is an integrated circuit ? Discuss the relative advantages and disadvantages of ICs over discrete assembly.
2. How will you make a monolithic IC ?
3. Explain how (i) a diode (ii) a transistor (iii) a resistor and (iv) a capacitor can be constructed in a monolithic integrated circuit.
4. Explain how electronic circuit consisting of different components can be constructed in a monolithic IC.
5. Write short notes on the following :
 (i) Epitaxial layer (ii) IC packages (iii) IC symbols

Discussion Questions

1. Why are ICs so cheap ?
2. Why do ICs require low power ?
3. Why cannot we produce ICs of greater power ?
4. Why are ICs more reliable than discrete assembly ?
5. Why is DIL IC package the most popular ?